



## Si9168 Demonstration Board

### FEATURES

- Voltage Mode Control
- 5-V to 10-V Input Voltage Range for  $V_{DD}$
- 5-V to 12.6-V Input Voltage Range for  $V_S$ -Boost
- Programmable PWM/PSM Control
- Up to 2-MHz Switching Frequency in PWM
- Synchronous Rectification in PWM
- Less Than 350- $\mu$ A  $I_{DD}$  in PSM
- Very High Efficiencies in Buck or Boost Modes
- Low Dropout Operation at 100% Duty Cycle In Buck Mode
- Integrated Soft-Start

### SYNCHRONIZATION

- Logic Controlled Micro Power Shutdown Current  $<2 \mu$ A
- Fast Line and Load Transient Response
- Available in 16-Lead TSSOP Package
- 2-Cell Li+ or 6-Cell NiCd / NiMH Operation

### SPECIFICATIONS:

**Si9168DB-K1**— $V_{IN} = 5$  to 10 V,  $V_{OUT} = 3.6$ -V/1.5-A Buck

**Si9168DB-K2**— $V_{IN} = 5$  to 10 V,  $V_{OUT} = 3.6$ -V/2.5-A Buck

**Si9168DB-S1**— $V_{IN} = 5$  to 7.2 V,  $V_{OUT} = 7.2$ -V/2.5-A Boost

### DESCRIPTION

The Si9168 is a high-frequency synchronous dc-to-dc controller designed for higher-power buck or boost conversion applications in end products running off 2-cell Lithium Ion or 6-cell NiCd or NiMH battery packs. Like the lower-power Si9167, the Si9168 is capable of operating at up to 2 MHz with a variety of drivers. Its high-frequency operation, strong totem pole drivers, selectable PWM/PSM operation modes, integrated under-voltage lockout, and soft-start features make the Si9168 suitable for 1-A to 10-A conversion applications, where size and cost are at prime importance.

To fully demonstrate the capability of the product, the Si9168 demonstration boards are available in three different versions. The buck converters provide 3.6-V nominal outputs and the boost converter output voltage is set at 7.2 V. The input source can be a 2-cell Li+, 6-cell NiCd/NiMH battery pack or dc supply. The set frequency in PWM for both buck and boost converter

is 850-kHz nominal to optimize the efficiency performance. Higher or lower frequency can be programmed by using  $R_{OSC}$  (R5) or synchronized with external clock. The demo boards can be easily modified to obtain the optimum efficiency at the rated load condition, by choosing the right MOSFET in respective packages.

The demonstration boards use all surface mount components and are fully assembled and tested for quick evaluation. Jumpers, test points and terminals are provided for the easy selection of operating mode and to observe waveform and inserting the error signal for the closed loop response.

Included in this document are the Bill-Of-Materials, Schematics, PCB Layout of the Demo Boards and actual waveforms/graphs.

*The demonstration board layout is available in Gerber file format. Please contact your Vishay Siliconix sales representative or distributor for a copy.*

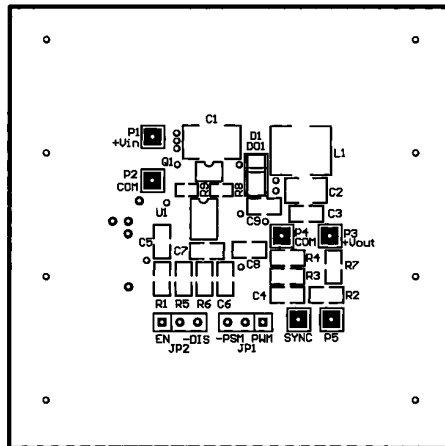
### ORDERING INFORMATION:

**Si9168DB-K1**— $I_{OUT} 1.5$  A – Buck

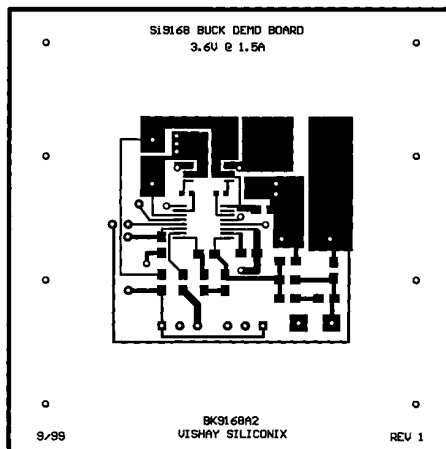
**Si9168DB-K2**— $I_{OUT} 2.5$  A – Buck

**Si9168DB-S1**— $I_{OUT} 2.5$  A – Boost

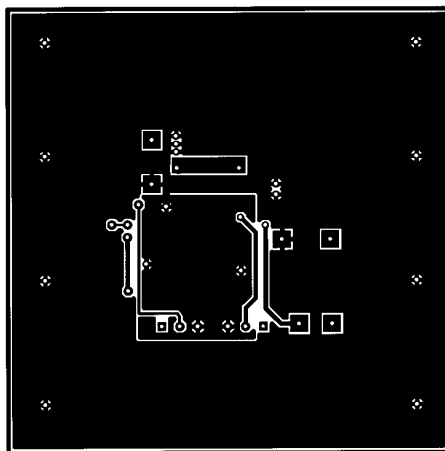




**FIGURE 2.** Si9168DB-K1 , Silk Screen

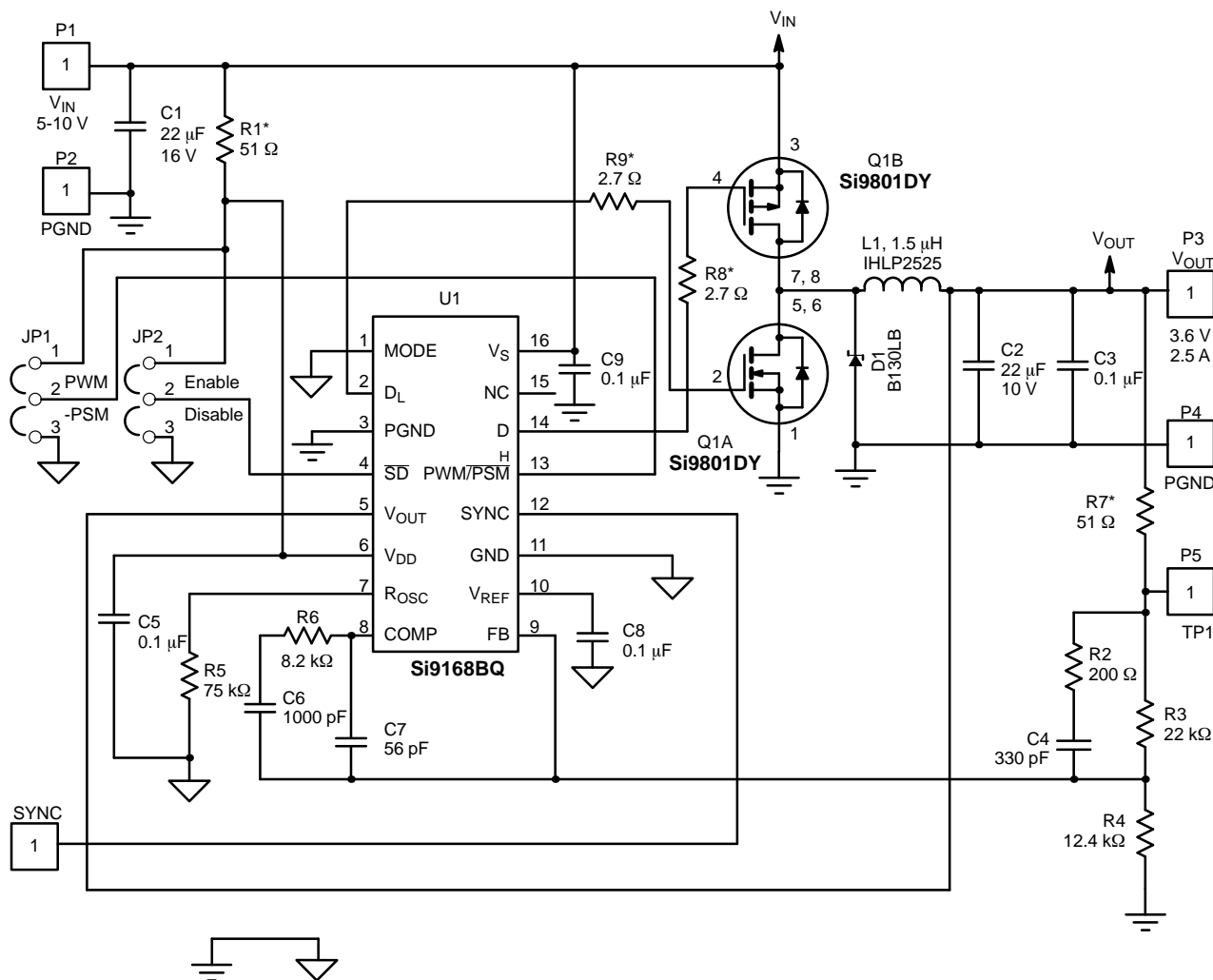


**FIGURE 3.** Si9168DB-K1, Top Layer



**FIGURE 4.** Si9168DB-K1, Bottom Layer

**APPLICATION SCHEMATIC AND PCB LAYOUT—SI9168DB-K2**



JP1: PWM/ $\overline{\text{PSM}}$  to  $V_{IN}$  for PWM mode;  
PWM/ $\overline{\text{PSM}}$  to GND for PSM mode.

JP2:  $\overline{\text{SD}}$  to  $V_{IN}$  for converter enable mode;  
 $\overline{\text{SD}}$  to GND for shutdown mode.

\* = Optional

**FIGURE 5.** Si9168DB-K2, 3.6- $V_{OUT}$ /2.5-A Buck Regulator

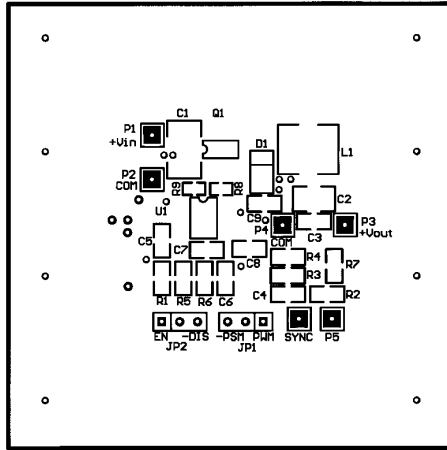


FIGURE 6. Si9168DB-K2, Silk Screen

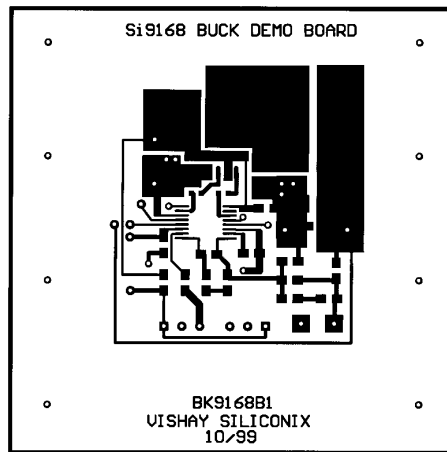


FIGURE 7. Si9168DB-K2, Top Layer

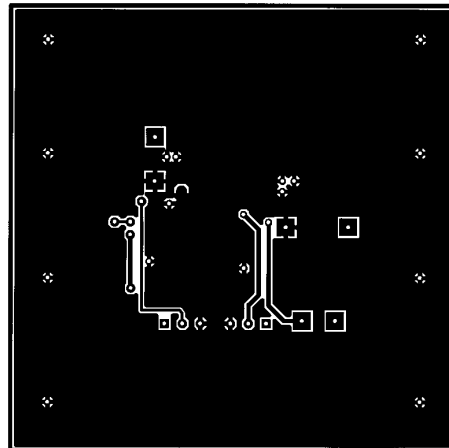
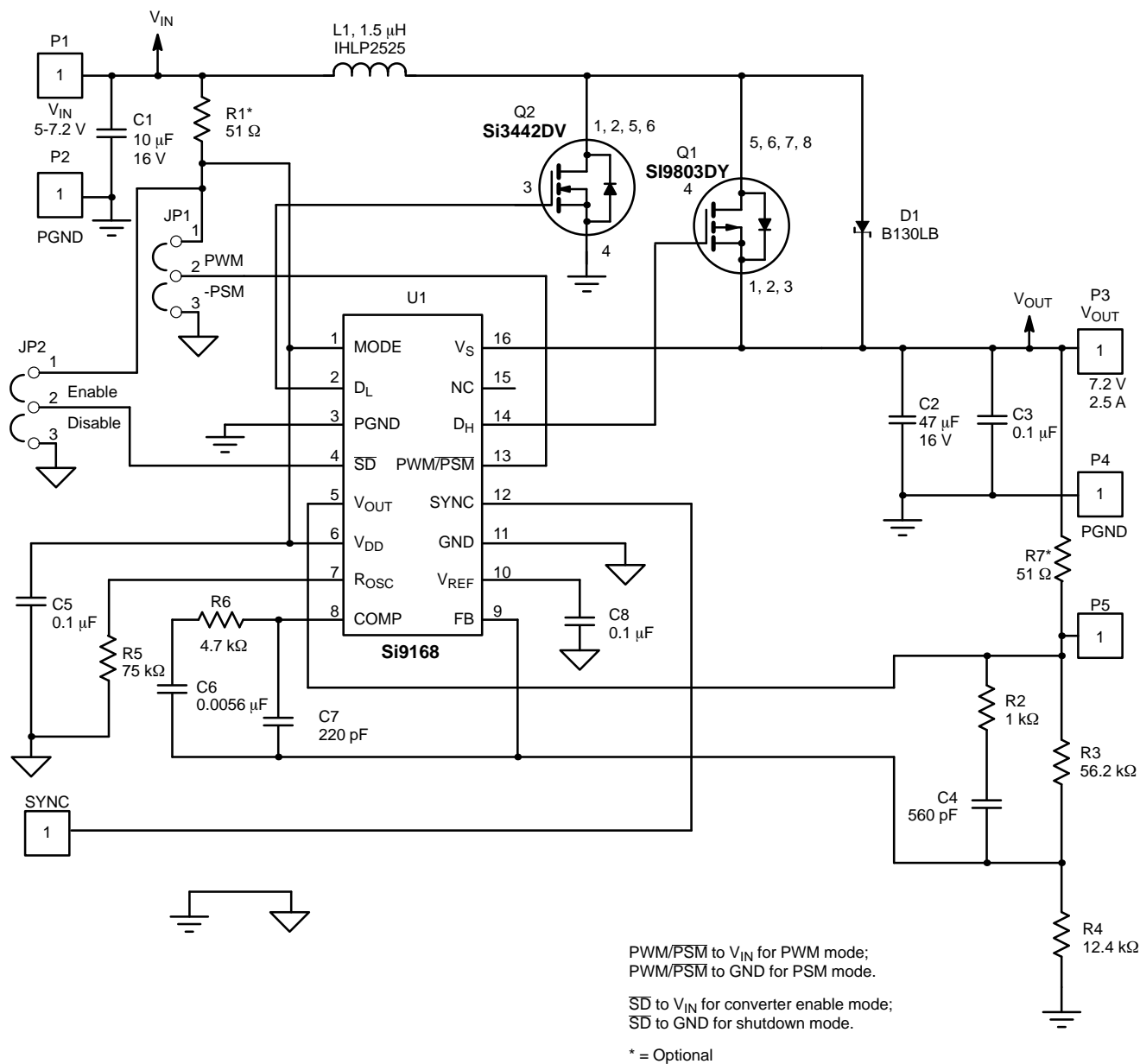
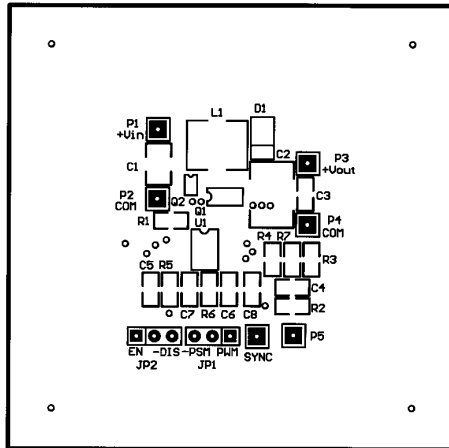


FIGURE 8. Si9168DB-K2, Bottom Layer

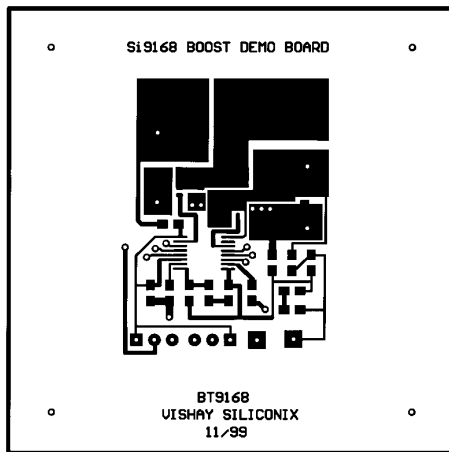
**APPLICATION SCHEMATIC AND PCB LAYOUT—SI9168DB-S1**



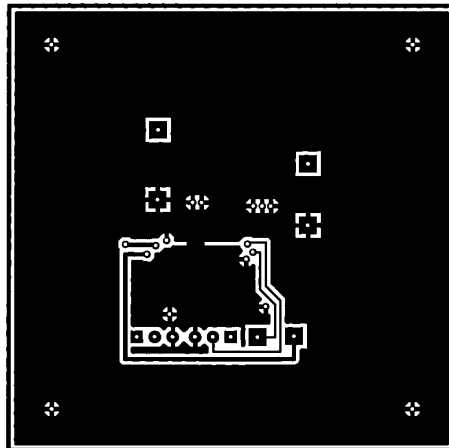
**FIGURE 9.** Si9168DB-S1, 7.2- $V_{OUT}$ /2.5-A Boost Regulator



**FIGURE 10.** Si9168DB-S1 , Silk Screen



**FIGURE 11.** Si9168DB-S1 , Top Layer

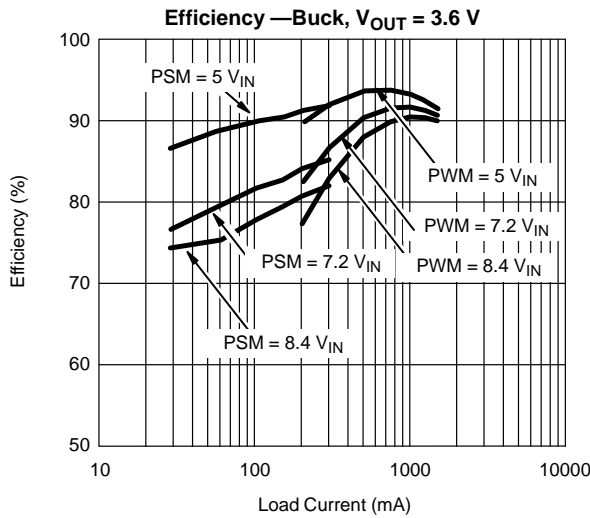


**FIGURE 12.** Si9168DB-S1 , Bottom Layer

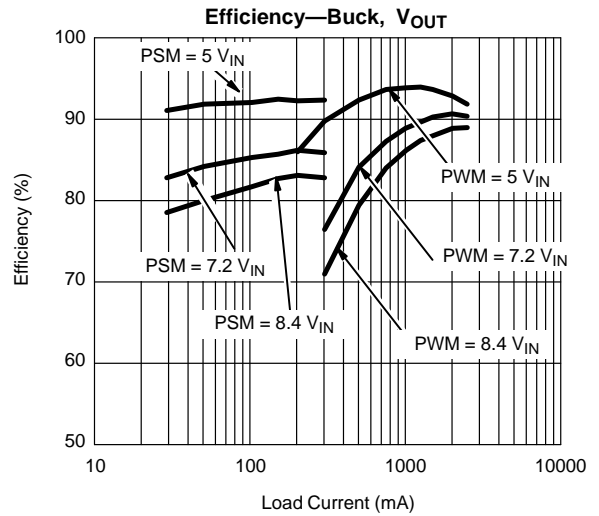
**ELECTRICAL PERFORMANCE AND TYPICAL WAVEFORMS**

**Efficiency**

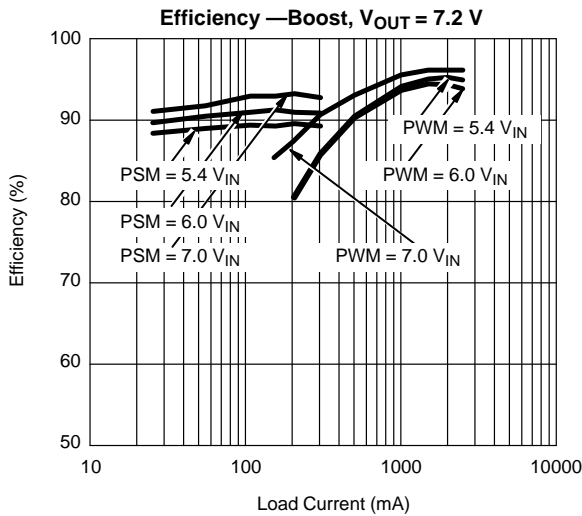
The demo board is designed for the optimum efficiency performance without sacrificing the cost and form factor issues. Figures 13, 14 and 15 depict the efficiency performance of demo boards in PSM and PWM operation.



**FIGURE 13.** Efficiency Si9168DB-K1, 1.5-A  $I_{OUT}$  Buck Regulator



**FIGURE 14.** Efficiency Si9168DB-K3, 2.5-A  $I_{OUT}$  Buck Regulator

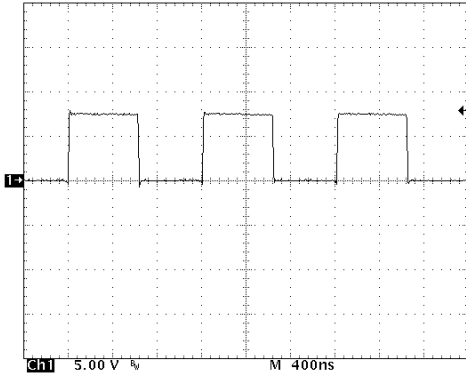


**FIGURE 15.** Efficiency Si9168DB-S1, 2.5-A  $I_{OUT}$  Boost

**Coil/Drain Waveforms**

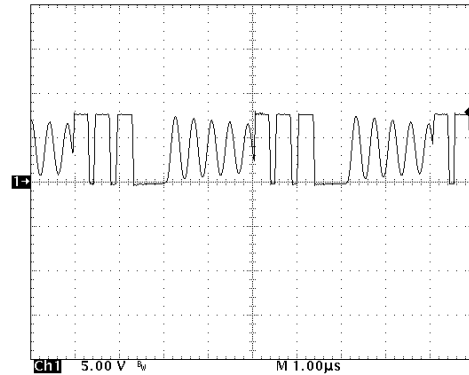
The Typical coil waveforms in PWM and PSM operation is shown in Figure 17 through Figure 19 for buck and boost conversion application. The outputs were loaded at the rated load in PWM and no spikes observed during the main switch turn on. Output load was 150 mA, in case of PSM. The coil/drain waveforms for the 2.5-A buck are similar to the 1.5-A buck converter.





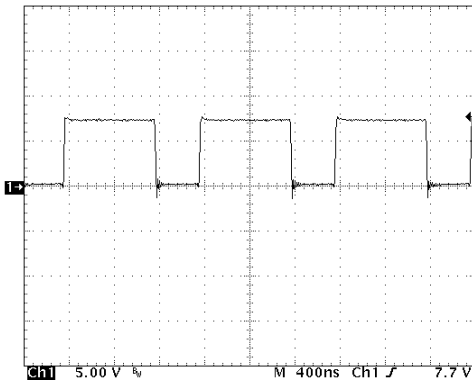
$V_{IN} = 7.2\text{ V}$   
 $V_{OUT} = 3.6\text{ V @ } 1.5\text{ A}$   
PWM

**FIGURE 16.** Coil/Drain Waveforms, PWM  
Si9168DB-K1, 1.5-A Buck Regulator



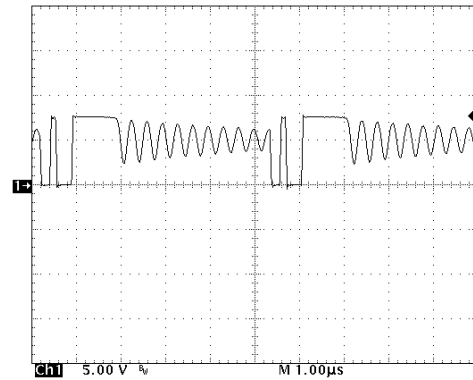
$V_{IN} = 7.2\text{ V}$   
 $V_{OUT} = 3.6\text{ V @ } 150\text{ mA}$   
PSM

**FIGURE 17.** Coil/Drain Waveforms, PSM  
Si9168DB-K1, 1.5-A Buck Regulator



$V_{IN} = 5\text{ V}$   
 $V_{OUT} = 7.2\text{ V @ } 2.5\text{ A}$   
PWM

**FIGURE 18.** Coil/Drain Waveforms, PWM  
Si9168DB-S1, 2.5-A Boost Regulator

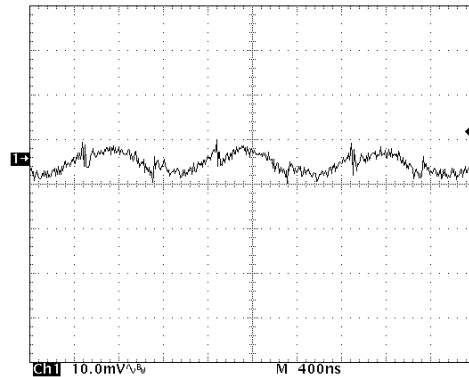


$V_{IN} = 5\text{ V}$   
 $V_{OUT} = 7.2\text{ V @ } 150\text{ mA}$   
PSM

**FIGURE 19.** Coil/Drain Waveforms, PSM  
Si9168DB-S1, 2.5-A Boost Regulator

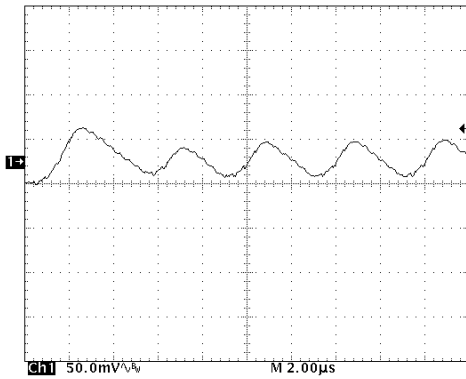
### PWM/PSM Output Ripple and Noise

Special care is required to correctly measure the ripple performance. A well-shielded probe and 100-MHz oscilloscope bandwidth is recommended to avoid any pick-up through the oscilloscope and falls reading. Also, connect the probe right across the output terminals P3 and P4 avoiding a long loop. The peak-to-peak ripple can be further reduced by adding a small additional LC (100 nH/1  $\mu$ F) after the output capacitor and sensing network. The boost converter ripple is measured right across the output capacitor C2, with 20-MHz oscilloscope bandwidth.



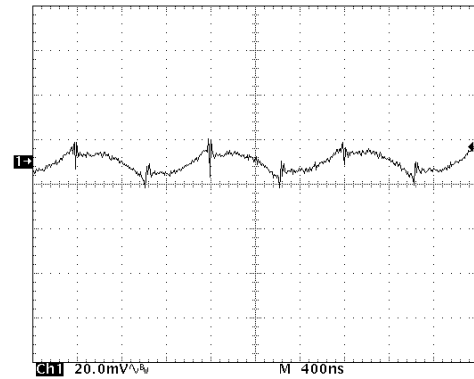
$V_{IN} = 7.2\text{ V}$   
 $V_{OUT} = 3.6\text{ V @ } 1.5\text{ A}$   
PWM

**FIGURE 20.** Output Ripple, PWM  
Si9168DB-K1, 1.5-A Buck



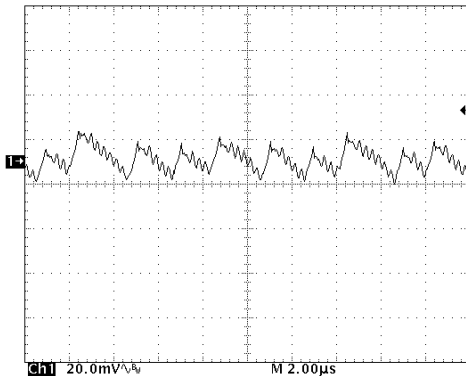
$V_{IN} = 7.2\text{ V}$   
 $V_{OUT} = 3.6\text{ V @ } 150\text{ mA}$   
 PSM

**FIGURE 21.** Output Ripple, PSM  
 Si9168DB-K1, 1.5-A Buck



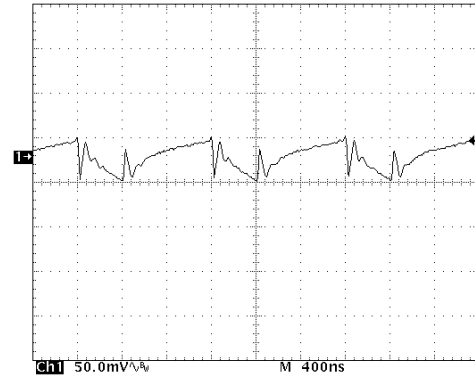
$V_{IN} = 7.2\text{ V}$   
 $V_{OUT} = 3.6\text{ V @ } 2.5\text{ A}$   
 PWM

**FIGURE 22.** Output Ripple, PWM  
 Si9168DB-K2, 2.5-A Buck



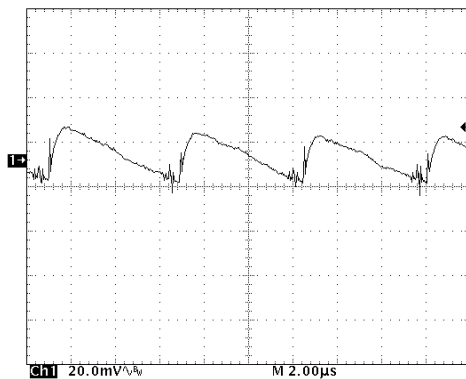
$V_{IN} = 7.2\text{ V}$   
 $V_{OUT} = 3.6\text{ V @ } 150\text{ mA}$   
 PSM

**FIGURE 23.** Output Ripple, PSM  
 Si9168DB-K2, 2.5-A Buck



$V_{IN} = 5\text{ V}$   
 $V_{OUT} = 7.2\text{ V @ } 2.5\text{ A}$   
 PWM

**FIGURE 24.** Output Ripple, PWM  
 Si9168DB-S1, 2.5-A Boost

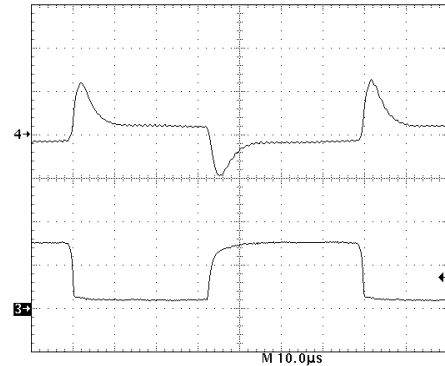


$V_{IN} = 5\text{ V}$   
 $V_{OUT} = 7.2\text{ V @ } 150\text{ mA}$   
 PSM

**FIGURE 25.** Output Ripple, PSM  
 Si9168DB-S1, 2.5-A Boost

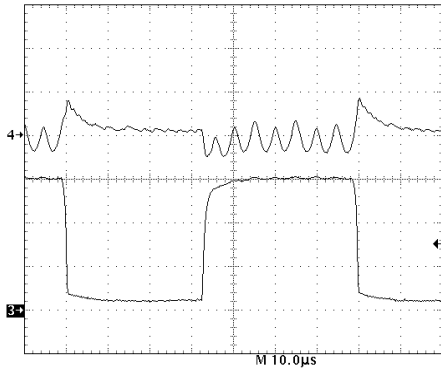
## Dynamic Load Response

The application circuit is compensated with Level 3 network for optimum closed loop bandwidth. The load transients are applied at a high slew rate of  $1 \text{ A}/\mu\text{S}$  and output voltage is monitored right at the output pins P3 and P4. Refer to Figures 26 through 30 for the dynamic load behavior in PWM/PSM operation for buck and boost configuration.



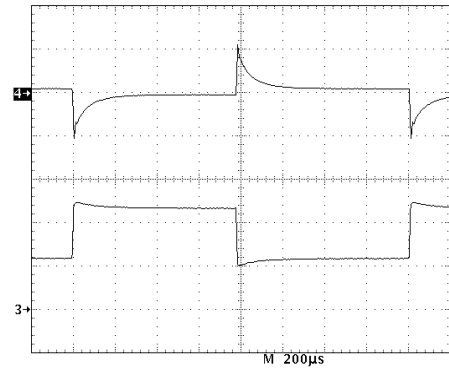
$V_{IN} = 7.2 \text{ V}$ ,  $V_O = 3.6 \text{ V}$   
 Slew Rate –  $1 \text{ A}/\mu\text{sec}$   
 $I_{STEP} = 0.3 - 1.5 \text{ A}$   
 Ch 3 – Load ( $1 \text{ A}/\text{div}$ )  
 Ch 4 – Output ( $200 \text{ mV}/\text{div}$ )

**FIGURE 26.** Transient Load Response, PWM  
 Si9168DB-K1, 1.5-A Buck Regulator



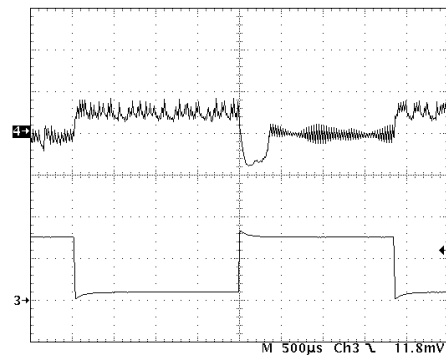
$V_{IN} = 7.2 \text{ V}$ ,  $V_O = 3.6 \text{ V}$   
 Slew Rate –  $1 \text{ A}/\mu\text{sec}$   
 $I_{STEP} = 25 - 300 \text{ mA}$   
 Ch 3 – Load ( $100 \text{ mA}/\text{div}$ )  
 Ch 4 – Output ( $100 \text{ mV}/\text{div}$ )

**FIGURE 27.** Transient Load Response, PSM  
 Si9168DB-K1, 1.5-A Buck Regulator



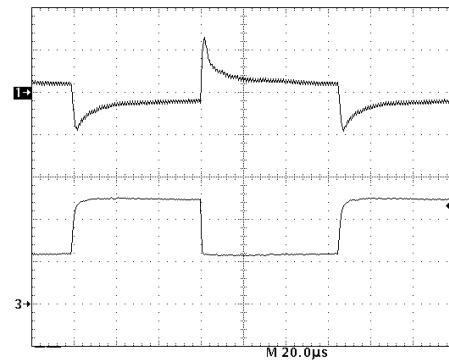
$V_{IN} = 5.4 \text{ V}$ ,  $V_{OUT} = 7.2 \text{ V}$   
 Slew Rate –  $1 \text{ A}/\mu\text{sec}$   
 $I_{STEP} = 1.25 - 2.5 \text{ A}$   
 Ch 3 – Load ( $1 \text{ A}/\text{div}$ )  
 Ch 4 – Output ( $200 \text{ mV}/\text{div}$ )

**FIGURE 28.** Transient Load Response, PWM  
 Si9168DB-S1, 2.5-A Boost Regulator



$V_{IN} = 5.4 \text{ V}$ ,  $V_{OUT} = 7.2 \text{ V}$   
 Slew Rate –  $1 \text{ A}/\mu\text{sec}$   
 $I_{STEP} = 25 - 300 \text{ mA}$   
 Ch 3 – Load ( $200 \text{ mA}/\text{div}$ )  
 Ch 4 – Output ( $50 \text{ mV}/\text{div}$ )

**FIGURE 29.** Transient Load Response, PSM  
 Si9168DB-S1, 2.5-A Boost Regulator



$V_{IN} = 7.2 \text{ V}$   
 $I_{STEP} = 1.25 - 2.5 \text{ A}$   
 Slew Rate =  $1 \text{ A}/\mu\text{sec}$   
 Ch 1 – Output ( $100 \text{ mV}/\text{div}$ )  
 Ch 3 – Load ( $1 \text{ A}/\text{div}$ )

**FIGURE 30.** Transient Load Response, PWM  
 Si9168DB-K2, 2.5-A Buck Regulator

**TABLE 3. BILL-OF-MATERIALS—Si9168DB-K1**

	Qty	Designator	Part Type	Description	Footprint	Vendor Part #	Manufacturer
1	2	R1, R7	51 $\Omega$	Resistor, 1/8 W, 1%	0805	CRCW08055100FRT1	Vishay Dale
2	1	R2	200 $\Omega$	Resistor, 1/8 W, 1%	0805	CRCW08052000FRT1	Vishay Dale
3	1	R3	22 k $\Omega$	Resistor, 1/8 W, 1%	0805	CRCW08052201FRT1	Vishay Dale
4	1	R4	12.4 k $\Omega$	Resistor, 1/8 W, 1%	0805	CRCW08051242FRT1	Vishay Dale
5	1	R5	75 k $\Omega$	Resistor, 1/8 W, 1%	0805	CRCW08057502FRT1	Vishay Dale
6	1	R6	8.2 $\Omega$	Resistor, 1/8 W, 1%	0805	CRCW08058201FRT1	Vishay Dale
7	2	R8, R9	5.6 $\Omega$	Resistor, 1/8 W, 1%	0603	CRCW06032R70JRT1	Vishay Dale
8	1	C1	22 $\mu$ F	CAP, CER, 16 V	2210	C25Y5U1C226Z	Tokin
9	1	C2	10 $\mu$ F	CAP, CER, 10V	1210	GRM42-2X5R106K010	Murata
10	4	C3, C5, C8, C9	0.1 $\mu$ F	CAP, CER	0805	VJ0805Y104KXXAT	Vishay Vitramon
11	1	C4	330 pF	CAP, CER	0805	VJ0805Y331KXXAT	Vishay Vitramon
12	1	C6	1000 pF	CAP, CER	0805	VJ0805Y102KXXAT	Vishay Vitramon
13	1	C7	56 pF	CAP, CER	0805	VJ0805Y560KXXAT	Vishay Vitramon
14	1	D1 (NU)	B130LB	Schottky Diode	SMB	B130LB	Vishay Liteon
15	1	D01	MBR0520T1	Schottky Diode	SOD-123	MBR0520T1	Motorola
16	1	L1	4.7 $\mu$ H	4.7 $\mu$ H Inductor	IHLP2525	IHLP2525-4.7uH	Vishay Dale
17	1	U1	Si9168	Power IC	TSSOP-16	Si9168BQ - T1	Vishay Siliconix
18	1	Q1	Si6803DQ	Dual N- and P-Channel	TSSOP-8	Si6803DQ	Vishay Siliconix



**TABLE 4. BILL-OF-MATERIALS—Si9168DB-K2**

	Qty	Designator	Part Type	Description	Footprint	Vendor Part #	Manufacturer
1	2	R1, R7	51 Ω	Resistor, 1/8 W 1%	0805	CRCW08055100FRT1	Vishay Dale
2	1	R2	200 Ω	Resistor, 1/8 W, 1%	0805	CRCW08052000FRT1	Vishay Dale
3	1	R3	22 kΩ	Resistor, 1/8 W, 1%	0805	CRCW08052201FRT1	Vishay Dale
4	1	R4	12.4 kΩ	Resistor, 1/8 W, 1%	0805	CRCW08051242FRT1	Vishay Dale
5	2	R5	75 kΩ	Resistor, 1/8 W, 1%	0805	CRCW08057502FRT1	Vishay Dale
6	1	R6	8.2 kΩ	Resistor, 1/8 W, 1%	0805	CRCW08058201FRT1	Vishay Dale
7	2	R8, R9	2.7 Ω	Resistor, 1/8 W, 5%	0603	CRCW06032R70JRT1	Vishay Dale
8	2	C1, C2	22 μF	CAP, CER, 16 V	2210	C25Y5U1C226Z	Token
9	4	C3, C5, C8, C9	0.1 μF	CAP, CER	0805	VJ0805Y104KXXAT	Vishay Vitramon
10	1	C4	330 pF	CAP, CER	0805	VJ0805Y331KXXAT	Vishay Vitramon
11	1	C6	1000 pF	CAP, CER	0805	VJ0805Y102KXXAT	Vishay Vitramon
12	1	C7	56 pF	CAP, CER	0805	VJ0805Y560KXXAT	Vishay Vitramon
13	1	D1	B130LB	Schottky Diode	SMB	B130LB	Vishay Liteon
14	1	L1	1.5 μH	1.5-μH Inductor	L_IHLP2525	IHLP2525-1.5 μH	Vishay Dale
15	1	U1	Si9168	Power IC	TSSOP-16	Si9168BQ-T1	Vishay Siliconix
16	1	Q1	Si9801DY	Single P-Channel MOSFET	SO-8	Si9801DY	Vishay Siliconix

**TABLE 5. BILL-OF-MATERIALS—Si9168DB-S1**

Item	Qty	Designator	Part Type	Description	Footprint	Vendor Part #	Manufacturer
1	2	R1, R7	51 $\Omega$	Resistor, 1/8 W 1%	0805	CRCW080551R0FRT1	Vishay Dale
2	1	R2	1 k $\Omega$	Resistor, 1/8 W, 1%	0805	CRCW08051002FRT1	Vishay Dale
3	1	R3	56.2 k $\Omega$	Resistor, 1/8 W, 1%	0805	CRCW08055622FRT1	Vishay Dale
4	1	R4	12.4 k $\Omega$	Resistor, 1/8 W, 1%	0805	CRCW08051242FRT1	Vishay Dale
5	1	R5	75 k $\Omega$	Resistor, 1/8 W, 1%	0805	CRCW08057502FRT1	Vishay Dale
6	1	R6	4.7 k $\Omega$	Resistor, 1/8 W, 1%	0805	CRCW08054701FRT1	Vishay Dale
7	1	C1	10 $\mu$ F	CAP, CER, 25 V	1210	GRM43-2X5R106K025	Murata
8	1	C2	47 $\mu$ F	CAP, CER, 16 V	2220	C55Y5U1C476Z	Tokin
9	3	C3, C5, C8	0.1 $\mu$ F	CAP, CER, X7R, 50 V, 10%	0805	VJ0805Y104KXAAT	Vishay Vitramon
10	1	C4	560 pF	CAP, CER, X7R, 50 V, 10%	0805	VJ0805Y561KXAAT	Vishay Vitramon
11	1	C6	0.0056 $\mu$ F	CAP, CER, X7R, 50 V, 10%	0805	VJ0805Y562KXAAT	Vishay Vitramon
12	1	C7	220 pF	CAP, CER, X7R, 50 V, 10%	0805	VJ0805Y221KXAAT	Vishay Vitramon
13	1	D1	B130LB	Schottky Diode	SMB	B130LB	Vishay Liteon
14	1	L1	1.5 $\mu$ H	1.5 $\mu$ H Inductor	L_IHLP2525	IHLP-2525AH-1.5uH	Vishay Dale
15	1	U1	Si9168BQ	Power IC	TSSOP-16	Si9168BQ-T1	Vishay Siliconix
16	1	Q1	Si9803DY	P-Channel MOSFET	SO-8	Si9803DY	Vishay Siliconix
17	1	Q2	Si3442DV	N-Channel MOSFET	TSOP-6	Si3442DV	Vishay Siliconix